

Learning Activity #1:

Build a Model of a Truss Bridge

Overview of the Activity

In this learning activity, you will build a model truss bridge that has already been designed for you. When construction is complete, you will load the bridge to determine if it performs as its designer intended. With the load in place, you will be able to observe how the structure works—how the various structural members work together to carry the load safely and efficiently. And at the end of the project, you will save the model as evidence of your bridge-building skill. Don't break it! We will be using it again in subsequent learning activities.

Why?

Design is the essence of engineering. The only way to truly appreciate the challenges and rewards of engineering is to actively engage in the creative process of design. So why, in this learning activity, will we devote considerable effort to building a bridge that has already been designed by someone else? It is true that building an existing design will not allow you to exercise a lot of creativity; nonetheless, this activity will provide you with valuable preparation for learning how to design a structure. Building an existing design will allow you to:

- Learn many key concepts about trusses and structural behavior that you'll use when you design your own bridge in Learning Activity #5.
- Familiarize with the engineering characteristics of a rather unique building material—cardboard from a manila file folder.
- Learn some special construction techniques appropriate for this material.
- Work with confidence, knowing that your bridge will carry the prescribed loading successfully, as long as you build the structure with care.
- Learn about the challenges faced by real-world construction contractors, who are often required to build structures that have been designed by someone else.

Learning Objectives

As a result of this learning activity, you will be able to do the following:

- Explain what a *truss* is.
- Identify the major components of a truss bridge.
- Identify the types of truss bridges.
- Explain the following fundamental structural engineering concepts: *force, load, reaction, equilibrium, tension, compression, and strength*.
- Explain how a truss bridge works—how each individual component contributes to the ability of the entire structure to carry a load.
- Explain the roles of the four key players in the design-construction process—the *Owner, the Design Professional, the Constructor, and the Project Manager*.
- Explain how construction quality affects the performance of a structure.

Information

1. Component Parts of a Truss Bridge

What is a Truss?

A **truss** is a structure composed of members connected together to form a rigid framework. **Members** are the load-carrying components of a structure. In most trusses, members are arranged in interconnected triangles, as shown below. Because of this configuration, truss members carry load primarily in **tension** and **compression**. (We'll discuss these terms in Section 3 below.) Because trusses are very strong for their weight, they are often used to span long distances. They have been used extensively in bridges since the early 19th century; however, truss bridges have become somewhat less common in recent years. Today trusses are often used in the roofs of buildings and stadiums, in towers, construction cranes, and many similar structures and machines.

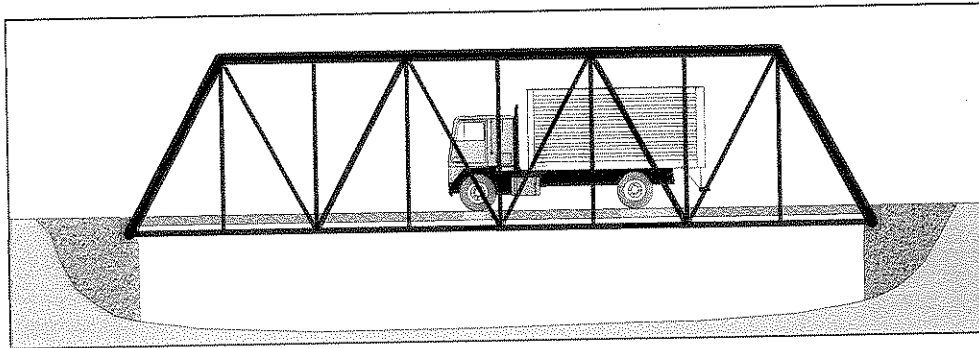

A typical truss bridge. Note that the structure is composed entirely of interconnected triangles.

Trusses, like all structures, are designed by civil engineers with special expertise in structural analysis and design. These men and women are called **structural engineers**.

Component Parts

The major components of a typical truss bridge are illustrated in the two diagrams below. The **elevation view** shows the bridge from the side. The **isometric view** is a three-dimensional representation of the structure. Note that certain members are *only* visible in the isometric view.

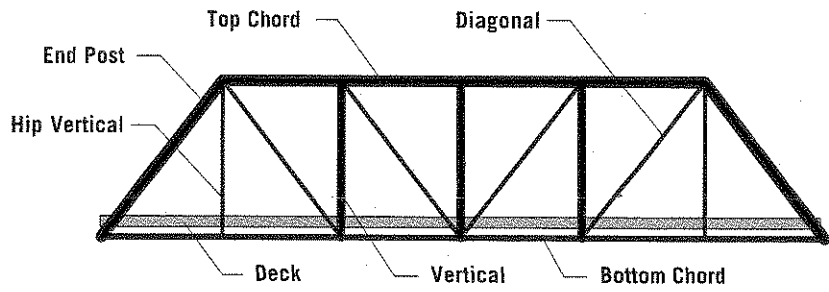

Component parts of a typical truss bridge - Elevation View

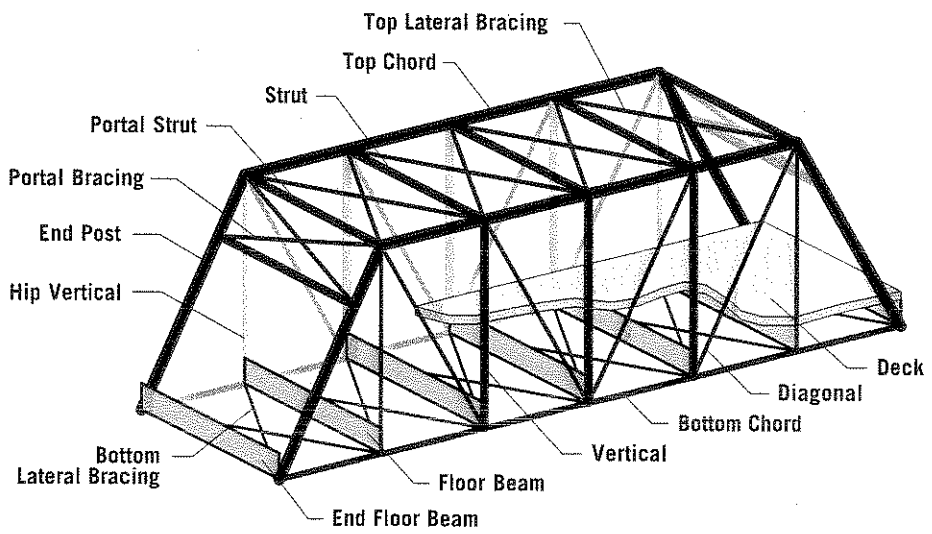

Component parts of a typical truss bridge - Isometric View ¹

The three-dimensional bridge structure has two main load-carrying trusses. Each truss is composed of a **top chord**, a **bottom chord**, and several **verticals** and **diagonals**. The two trusses are connected together by a series of transverse members—**struts**, **lateral bracing**, and **floor beams**.

In early truss bridges, all of these members would have been made of wood or iron. Today they are usually made of steel. Modern steel truss members are manufactured in a wide variety of shapes and sizes. A few common examples are shown on the following page. The model truss we will be building uses both **solid bars** and **hollow tubes**. When we load-test our model, we'll see why one truss often uses two different types of members.

¹ Based on "Truss Identification: Nomenclature," Historic American Engineering Record HAER T1-1, National Park Service, 1976.

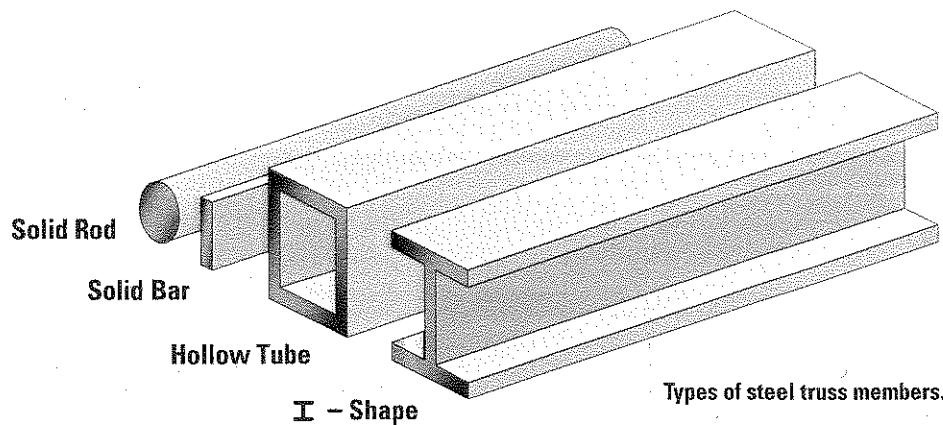

One major component of a truss bridge that is usually *not* made of steel is the **deck**—the flat surface between the two main trusses. (In the isometric drawing, only part of the deck is shown, so the structural members below it can be seen.) Bridge decks are usually made of concrete, but might also be built from wooden planks or steel grating. When vehicles or pedestrians cross a bridge, their weight is directly supported by the deck. The deck, in turn, is supported on the floor beams. The floor beams transmit the weight of the vehicles and pedestrians (and the weight of the deck) to the main trusses.

The truss drawings above do not show the **connections** that are used to join the structural members together. Even though the connections are not shown, they *are* important! They have a big influence on the ability of a structure to carry load. Indeed, inadequately designed connections have been the cause of several catastrophic structural failures in the U.S.²

There are two common types of structural connections used in trusses—**pinned connections** and **gusset plate connections**. Examples of each are shown in the photographs below. As the name suggests, the pinned connection uses a single large metal pin to connect two or more members together, much like the pin in a door hinge. In a gusset plate connection, members are joined together by one or two heavy metal **gusset plates**, which are attached to the individual members with rivets, bolts, or welds. Pinned connections were used extensively throughout the 19th century. Most modern bridges—including the model bridge we will be building here—use gusset plate connections.

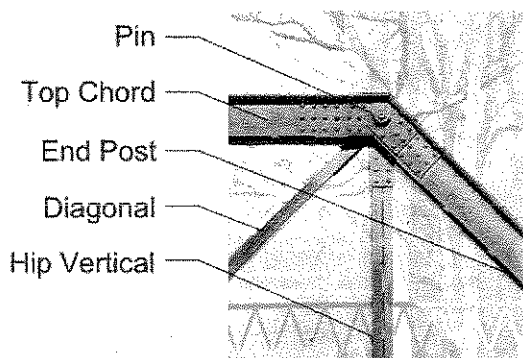

Typical pinned connection.

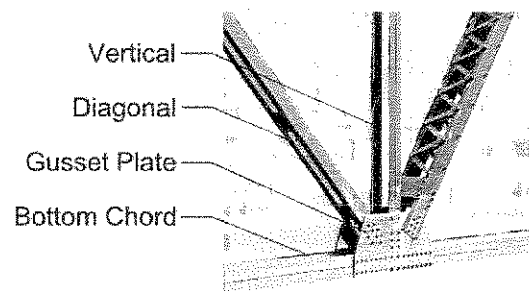

Typical gusset plate connection

Each of the bridge components described above has a specific purpose. All of the components work together to ensure that the bridge carries load safely and efficiently. In this learning activity, we will fabricate and assemble these various types of structural members and components, and we will observe how each one works.

² For more information on structural failures, see *Why Buildings Fall Down*, by Mario Savadori.

Foundations

Every structure must be supported on a firm **foundation**, which distributes the weight of the structure to the soil or rock below it. Bridges use two different types of foundations. The ends of a bridge usually rest on **abutments**, which serve two functions simultaneously—they support the bridge and also hold back the soil that is filled in behind them. If the bridge requires additional support in the middle of the gap, one or more **piers** are used, as shown below. Abutments and piers are normally made of concrete.

All structural foundations are designed by civil engineers with special expertise in soils and foundations. These men and women are called **geotechnical engineers**.

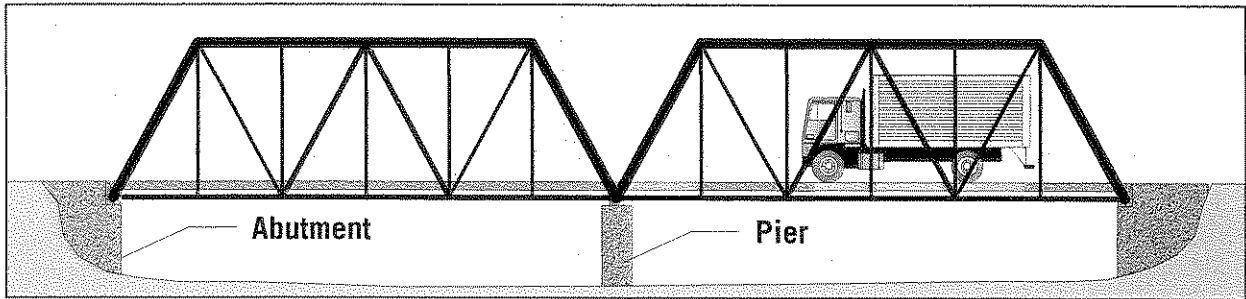

Types of bridge foundations.



Can you identify the component parts of a truss bridge?

Select any bridge pictured in the Gallery of Truss Bridges (Appendix A), and identify its major component parts—top and bottom chords, verticals, diagonals, floor beams, lateral bracing, struts, portal bracing, deck, abutments, and piers. (You will not be able to find every one of these components on every pictured bridge.)

2. Types of Truss Bridges

Truss bridges are grouped into three general categories, based on their deck location. If the deck is located at the level of the bottom chord, the bridge is called a **through truss**. A **pony truss** looks just like a through truss, except it is not as high and has no lateral bracing between the top chords. If the deck is located at the level of the top chord, the bridge is called a **deck truss**.

Trusses are also classified according to the geometric arrangement of their chords, verticals, and diagonals. The diagrams on the following page show 15 of the most common truss configurations, many of which were named for the 19th century engineers who developed them. On each diagram, the solid lines represent the main structural members in the truss. The dotted lines shown on some trusses represent supplemental members that may or may not be present on a particular bridge of this type. Designers sometimes use these lightweight diagonal members to more efficiently carry the weight of moving vehicles. The classification of a bridge is not affected by the presence or absence of these supplemental members.

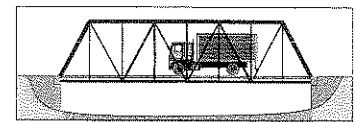

Through truss.

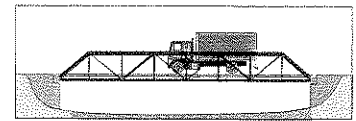

Pony truss.

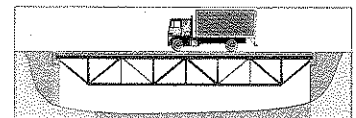

Deck truss.